

D151X

Bronze Gate Valve
Non rising stem

PN25

Features & Benefits

The D151X bronze gate valve offers a dependable and long service life across a wide variety of applications by virtue of its design and material composition.

- Non-rising stem design to minimise installation height
- Full bore design to ensure minimal pressure drop
- Adjustable gland packing for ease of maintenance
- Material selection results in superior dezincification (DZR) and corrosion resistance properties
- Body, bonnet and disc are made from low lead content bronze, typically 4-6%
- Conforms with BS EN12288:2010 and generally conforms with MSS SP 80.

Materials

PART	MATERIAL	SPECIFICATION	SIZES
Body	Bronze	BS EN 1982 (CC491K)	ALL
Bonnet	Bronze	BS EN 1982 (CC491K)	ALL
Stem	DZR Brass	BS EN 12164 CW602N	ALL
Disc	Bronze	BS EN 1982 (CC491K)	ALL
Stem Retainer	DZR Brass	BS EN 12164 CW602N	1/2 - 2
Stuffing Box	DZR Brass	BS EN 12164 CW602N	1/4 - 3/8, 2 1/2 - 3
Packing Ring	PTFE	-	ALL
Packing Nut	Brass	BS EN 12164 CW614N	ALL
Packing Gland	Brass	BS EN 12164 CW614N	1/4 - 3/8, 1 - 3
Handwheel	Aluminium	-	ALL
Identification Plate	Aluminium	-	ALL
Handwheel Nut	Brass	BS EN 12164 CW614N	ALL
Gasket	Asbestos Free	-	3

Dimensions & Weights

SIZE (inch)	A (mm)	B (mm)	C (mm)	D (mm)	WEIGHT (kg)	KV
1/4	46	75	45	86.7	0.27	-
3/8	46	75	45	86.7	0.26	-
1/2	50	78	52.3	93.0	0.27	21
3/4	54	84	60	103	0.38	39
1	62	105	65	127	0.59	66
1 1/4	71	111	70	139	0.89	116
1 1/2	77.5	130	78	163	1.31	162
2	87.5	153	92	193	2.09	281
2 1/2	106	235	103	286.2	5.62	411
3	113	251	121	310.3	7.89	635

PRESSURE RATING: PN25

TEMPERATURE OPERATING RANGE:
-10 to 186°C

UK END CONNECTION:

FIG. D151X: Taper threaded to BS EN 10226-2 (ISO 7-1) formerly BS 21

US END CONNECTION:

FIG. D151X.AT: ANSI B1.20.1

OPERATOR: Handwheel.

Gate valves are best for services that require infrequent valve operation, and where the disc is kept either fully opened or fully closed. They are not practical for throttling.

SPECIFICATION: Bronze Gate Valve, Non-Rising Stem, Solid Wedge, Screwed Bonnet, in accordance with BS EN 12288:2010, PN25 rated. Body, Bonnet and disc to Bronze to BS EN 1982 CC491K. DZR Brass Stem to CW602N. PTFE packing ring complete with Brass packing gland and nut design.

MSS SP80 CONFORMANCE: D151X meets the essential requirements of the Standard such as pressure temperature rating, functional attributes, material of construction, wall thickness and thread depth. D151X.AT complies with end connections as well.

The Valve is suitable for use in group 2 gases, group 1 and group 2 liquids, as defined by the Pressure Equipment Directive 2014/68/EU.*

* See page 159 for more information



D151X

Please note: the photograph & dimensional drawing denotes sizes 1/2" - 2" only.

Dimensional Drawing

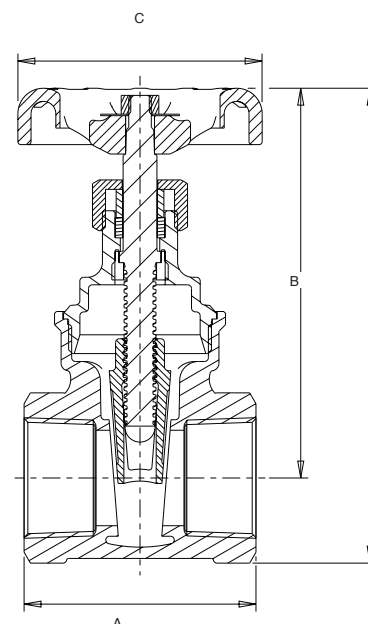

Pressure/Temperature Ratings

TEMPERATURE (°C)	-10 to 66	120	170	186
PRESSURE (BAR)	25.0	21.8	12.8	10.5

Intermediate pressure ratings shall be determined by interpolation.