

FILTRO INOX BRD X 150PSI

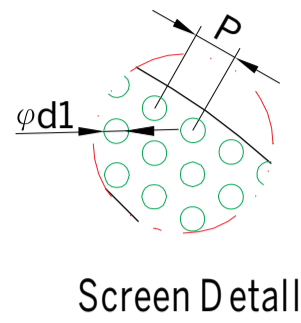

SIZE		d1		P	
inch	mm	inch	mm	inch	mm
2"	50	0.04	1	0.08	2
3"	80	0.04	1	0.08	2
4"	100	0.04	1	0.08	2
6"	150	0.12	3	0.2	5

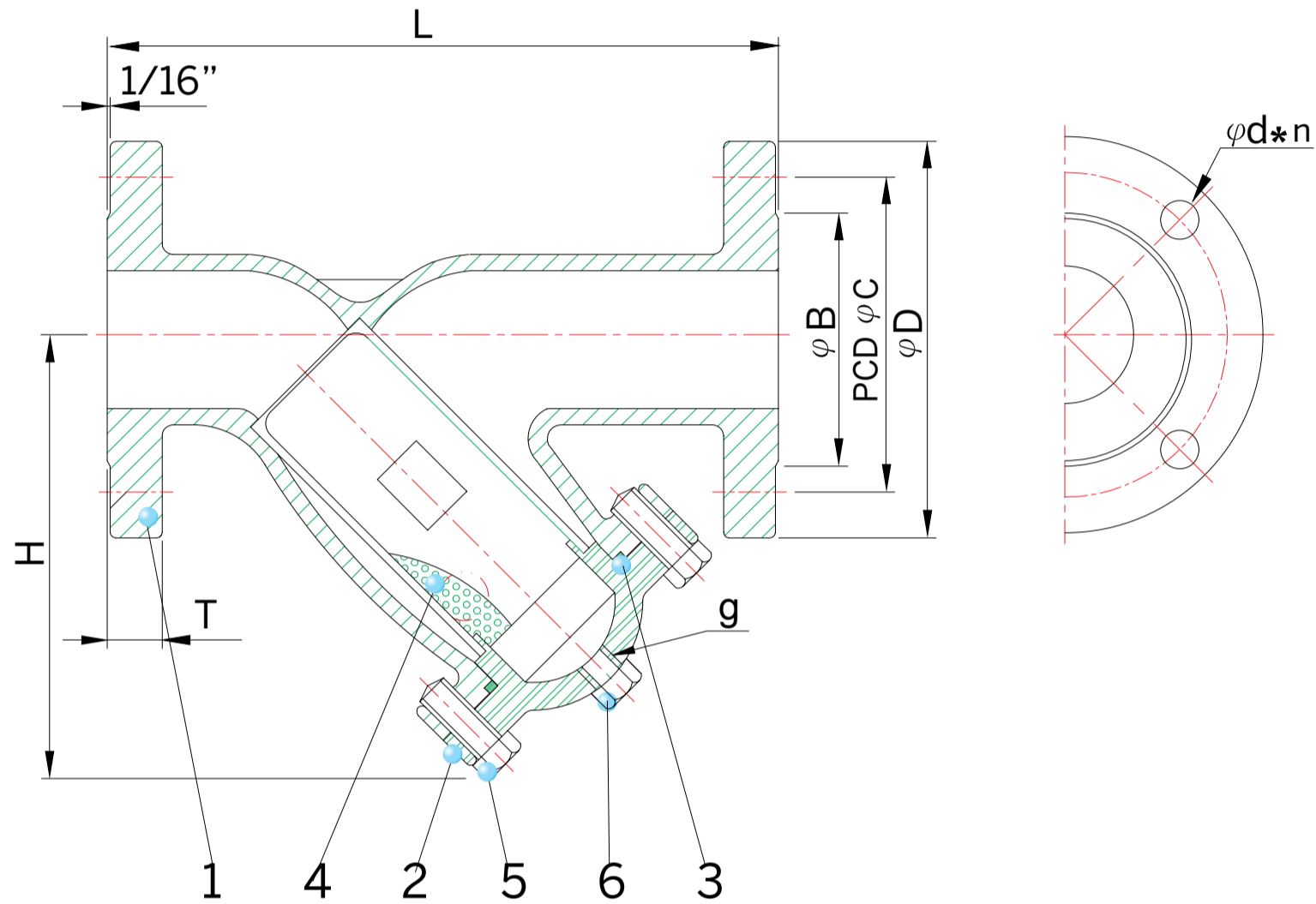

PART MATERIAL

1	BODY	ASTM A351 Gr.CF8M
2	CAP	ASTM A351 Gr.CF8M
3	GASKET	PTFE
4	SCREEN	*SS304
5	BOLT	ASTM A193 B8
6	PLUG	SS316

*316 SCREENS AVAILABLE UPON REQUEST

DESIGN FEATURES

Body	ASTM A351 Gr.CF8M
Screen	SS304
Gasket	PTFE
Flange Dimensions	ANSI B16.5 150#
TEST STANDARD	API 598

DIMENSION

SIZE		B		C		D		d		H		L		n	T		g	CV Factor	Weight	
inch	mm	inch	mm	inch	mm	inch	mm	inch	mm	inch	mm	inch	mm		inch	mm			Kg	Lb
2"	50	3.62	92	4.74	120.5	5.98	152	0.75	19	5.75	146	8.58	218	4	0.63	15.9	1/2"	500	13	28.6
2-1/2"	80	4.13	105	5.49	139.5	7	178	0.75	19	7.09	180	10.28	261	4	0.69	17.5	3/4"	850	23	50.6
3"	80	5	127	6.00	152.5	7.48	190	0.75	19	7.87	200	11.61	295	4	0.75	19.1	1"	1150	25	55.1
4"	100	6.18	157	7.5	190.5	9.02	229	0.75	19	9.45	240	14.21	361	8	0.94	23.9	1-1/2"	2120	33	72.7
6"	150	8.5	216	9.51	241.5	11	279	0.87	22	13.4	340	18.46	469	8	1	25.4	2"	5100	76	167.4

WWW.VANECO.COM.PE

Email: ventas@vaneco.com.pe

Oficina: Av. Andrés Bazzari 207 Urb. Maranga San Miguel

Almacén Principal: Avenida Nicolas Ayllón 2635 Interior C3

Central telefónica: (511) 5170130  948544608