

Class 300 • Union Bonnet • Plug Type Disc • Renewable Stainless Steel Seats

Figure 382P

Size Range:

¼" through 3"

Working Pressures Non-Shock:

300 psi Steam, Basic Rating

¼" to 2" - (6mm-50mm)

1000 psi Cold Working Pressure

¼" to 2" - (6mm-50mm)

600 psi Cold Working Pressure

2 ½" to 3" - (65mm-80mm)

Features

- Ideal for non-shock, severe service, such as throttling soot blower, blow-off, boiler feed, and drip and drain lines
- Union Bonnet
- Threaded Ends
- Plug Type Disc
- Back Seat
- 450 Brinell hardened Stainless Steel Seat Ring
- Valves 2" (50mm) and smaller have compact union bonnet; 2 ½" (65mm) and 3" (80mm) use bolted bonnet.
- MSS Specification SP-80

For more detailed features, refer to page 35.

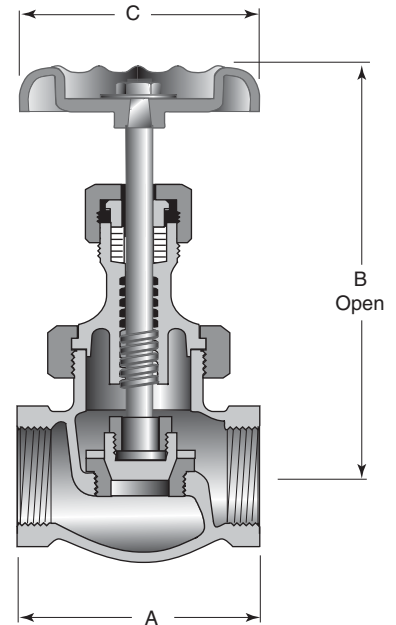

Principal Parts & Materials

Part	Sizes	Material	ASTM
Body	All	Bronze	B61 C92200
Bonnet	¼" - ¾"	Brass	B16 H02
Bonnet	½" - 3"	Bronze	B61 C92200
Disc & seat ring	All	Stainless Steel	A276 S42000
Stem	All	Bronze	B371 C69400

Dimensions and Weights

Inches (millimeters) - pounds (kilograms)

	¼ (6)	⅜ (10)	½ (15)	¾ (20)	1 (25)	1 ¼ (32)	1 ½ (40)	2 (50)	2 ½ (65)	3 (80)
A	1.97 (50)	1.97 (50)	2.63 (67)	2.99 (76)	3.51 (89)	4.04 (103)	4.57 (116)	5.72 (145)	7.28 (185)	8.70 (221)
B	4.43 (102)	4.43 (102)	4.09 (97)	5.10 (119)	5.58 (131)	6.42 (146)	7.17 (162)	7.48 (172)	8.44 (192)	9.79 (220)
C	2.13 (54)	2.13 (54)	2.50 (64)	2.98 (76)	3.02 (77)	3.68 (93)	4.63 (118)	5.24 (133)	6.97 (177)	7.00 (178)
WTS.	0.90 (0.39)	0.90 (0.39)	1.30 (0.59)	2.20 (1.00)	3.20 (1.45)	4.80 (2.18)	7.10 (3.22)	11.50 (5.20)	25.10 (11.39)	40.50 (19.37)