

BALL VALVE 2PC INOX 1000 WOG

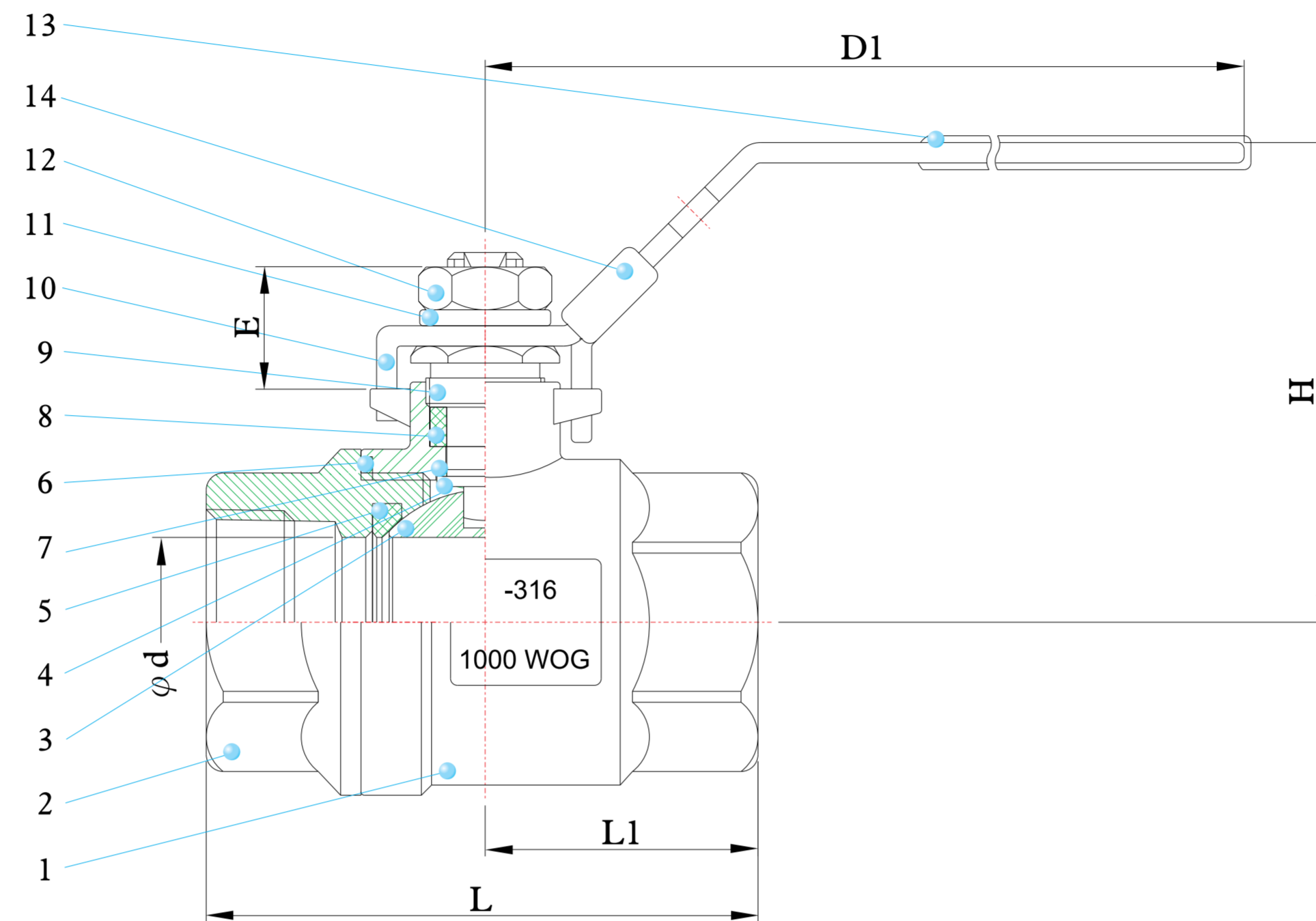
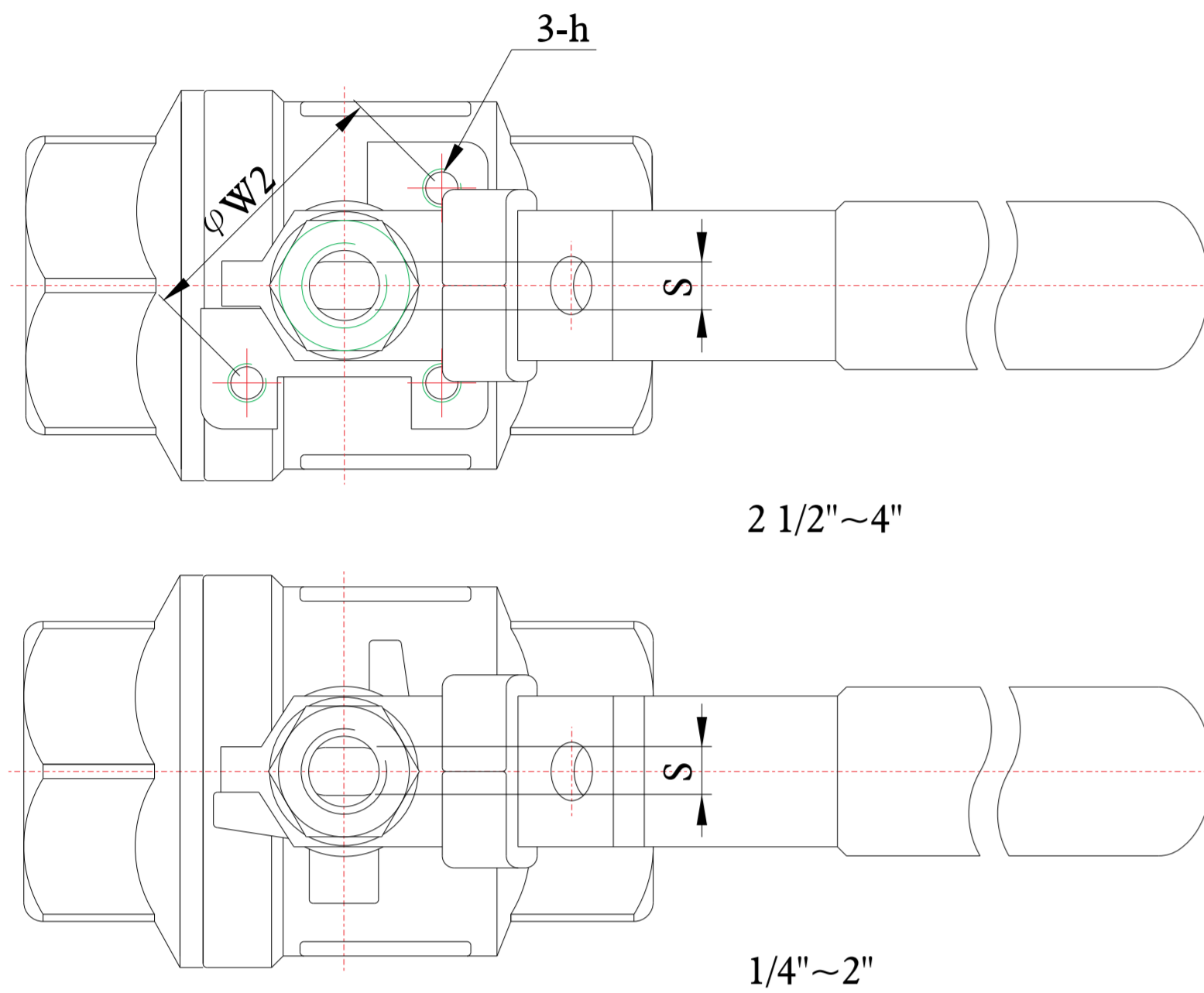

PART MATERIAL		
1	Body	ASTM A351Gr.CF8M
2	Cap	ASTM A351Gr.CF8M
3	Ball	ASTM A351Gr.CF8M
4	Stem	ASTM A276 Gr.316
5	Seat	PTFE+15% G/F
6	Gasket	PTFE
7	Thrust Washer	PTFE
8	Packing	PTFE
9	Gland	SS304
10	Handle	SS304
11	Handle Washer	SS304
12	Handle Nut	SS304
13	Handle Sleeve	VINYL GRIP
14	Locking Plate	SS304

DESIGN FEATURES

Steam Rating: 150psi WSP
Blow-out-proof stem design
Temperature Range: -50 °F to 450 °F
Options: Locking device
Test Standard: API 598
Vacuum Service to 29" Hg
Threaded Type: ANSI B1.20.1 (NPT), DIN 259/DIN 2999 SO228 BSP PT

DIMENSION

Size		d		E		L		L1		H		S		D1		W2		h (Option)	CV Factor	Weight	
inch	mm	inch	mm	inch	mm	inch	mm	inch	mm	inch	mm	inch	mm	inch	mm	inch	mm			Kg	Lb
1/4"	8	0.43	11	0.61	16	2.28	2.28	1.1	28.8	2.3	57	0.2	5.5	4.1	103			16	0.26	0.57	
3/8"	10	0.49	13	0.61	16	2.28	2.28	1.1	28.8	2.3	57	0.2	5.5	4.1	103			16	0.24	0.53	
1/2"	15	0.59	15	0.57	15	2.43	2.43	1.2	30.7	2.3	59	0.2	5.5	4.1	103			26	0.3	0.66	
3/4"	20	0.79	20	0.83	21	2.76	2.76	1.4	35	2.5	63	0.2	5.5	4.1	103			55	0.42	0.93	
1"	25	0.98	25	0.77	20	3.2	3.2	1.6	40.2	2.8	71	0.2	6.2	5	127			110	0.7	1.54	
1 1/4"	32	1.26	32	1.09	28	3.78	3.78	1.9	47.2	3	76	0.2	6.2	5	127			180	1.1	2.42	
1 1/2"	40	1.5	38	1.5	28	4.43	4.43	2.2	55.6	3.5	89	0.4	9.4	6	153			270	1.86	4.1	
2"	50	2	51	1.08	27	4.96	4.96	2.5	62.4	3.9	98	0.4	9.4	7.6	193			500	2.85	6.28	
2 1/2"	65	2.56	65	1.02	26	6.63	6.63	3.4	85	4.4	111	0.4	9.4	7.6	193	2.76	70	M8*P1.25	800	6.25	13.8
3"	80	3.15	80	1.5	38	7.54	7.54	3.8	95.9	4.9	124	0.5	12	11	279	4.02	102	M10*P1.5	1150	10.42	23
4"	100	3.94	100	1.89	48	8.52	8.52	4.3	108	6.6	169	0.5	16	13	335	4.02	102	M10*P1.5	2120	17.2	37.9

WWW.VANECO.COM.PE

Email: ventas@vaneco.com.pe

Oficina: Av. Andrés Razuri 207 Urb. Maranga San Miguel

Almacén Principal: Avenida Nicolás Ayllón 2635 – Interior C3

Central telefónica: (511) 5170130  948544608